

# LANE TECH SHEET

## Poly Vault Ladder with Handrail

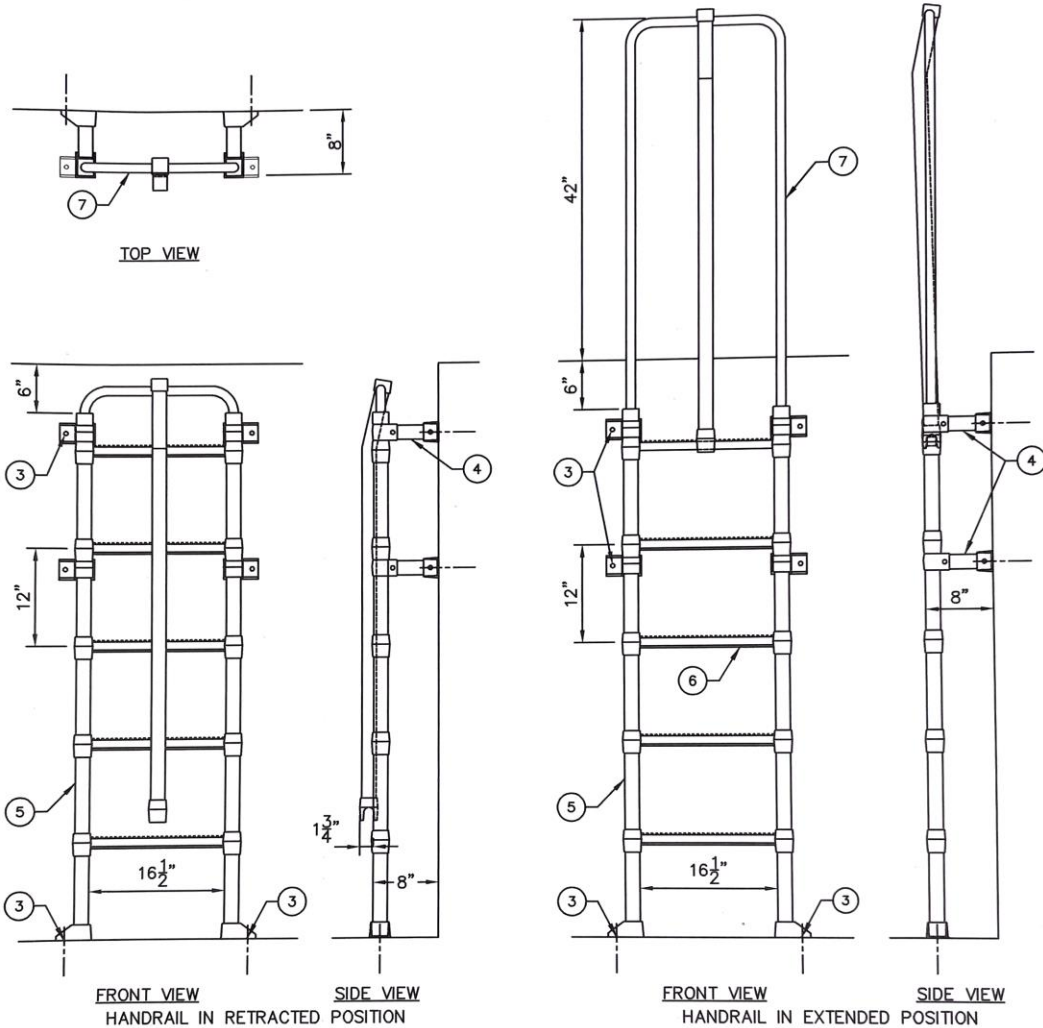

### LANE POLYPROPYLENE VAULT LADDER WITH PULL-UP HANDRAIL

#### NOTES:

1. LADDERS WITH PULL-UP HANDRAIL AVAILABLE IN 5 RUNG THROUGH 19 RUNG.
2. POLYPROPYLENE CONFORMS TO ASTM D-4101. LADDERS MEET ALL ASTM C-497 LOAD REQUIREMENTS AND OSHA 1910.26 AND 1910.27 SPECIFICATIONS.
3. FASTEN LADDER TO FLOOR AND WALL WITH 1/2"x 3-3/4" ANCHORS. ANCHORS TO BE INSTALLED PER MANUFACTURERS INSTRUCTIONS.
4. STANDARD ADJUSTABLE MOUNTING BRACKET - 8" O.D.
5. ALUMINUM REINFORCED COPOLYMER POLYPROPYLENE RAIL 1-3/4"x 1-3/4" DIA.
6. STEEL REINFORCED COPOLYMER POLYPROPYLENE RUNG 1-5/8"x 1-1/4" DIA. WITH MOLDED FINGER GRIPS, 12" C.C.
7. ALUMINUM AND STEEL REINFORCED COPOLYMER POLYPROPYLENE PULL-UP HANDRAIL.

LADDER MANUFACTURED BY LANE INTERNATIONAL CORPORATION  
P.O. BOX 925, TUALATIN, OREGON 800-666-0076

Drawing: 1  
Scale: None

Vault Ladder with  
Pull-Up Handrail

**LANE** INTERNATIONAL  
CORPORATION

P.O. Box 925 \* Tualatin, OR 98062  
503-692-9860 \* [www.laneinternational.com](http://www.laneinternational.com)